

# Series N700

- Lubrication • Air/Water • Assembly Operations
- Washdown • Air Tools • General Industrial Applications

**To handle 1/4" through 1/2" I.D. hose.**

- Narrow frame and compact mounting base.
- Non-sparking ratchet assembly.
- Declutching arbor to prevent damage from reverse winding.
- Standard inlet: 90° balanced pressure swivel joint, 1/2" female NPT threads.
- Standard outlet: 1/2" female NPT threads.
- Standard pressures to 3000 psi (207 bar), available up to 10,000 psi (690 bar) – must specify.
- Temperatures from -60°F to +250°F (-51°C to +121°C), optional temps to +400°F (+204°C) – must specify.
- 4-way roller assembly.
- Constant tension is available – consult factory.



Standard configuration shown

**PARTS DRAWING – ISO 79**

Model Number	Hose Capacity of Reel feet m				Approx. Weight lb. kg			Standard Roller Assy.	Reel Dimensions*** in. mm							
	I.D. in.	1/4	3/8	1/2	NET	UPS/ FedEx SHIP Wt.	Freight SHIP Wt.		A	B	C	E	F	G	H	X
	O.D. in. mm	6 16	10 19	13 22												
<b>N716-14-16-8C</b>	-	25	25	52	64*	87	N204	10	4	8	17.62	11.25	16.25	9.12	8	
	-	8	8	24	29	39		254	102	203	448	286	413	232	203	
<b>N716-16-17-10.5C</b>	-	35	35	55	67*	90	N204	10	4	10.5	18.5	11.25	17	9.12	8	
	-	11	11	25	30	41		254	102	267	470	286	432	232	203	
† <b>N716-17-18-8L</b>	-	50†	50†	63	75*	105	N204	10	4	8	19.5	11.25	17.5	9.12	8	
	-	15†	15†	29	34	48		254	102	203	495	286	445	232	203	
<b>N716-19-20-10.5J</b>	-	50	50	64	82*	99	N204	10	4	10.5	20.75	11.25	20	10.62	8	
	-	15	15	29	37	45		254	102	267	527	286	508	270	203	
<b>N716-23-24-15.5J</b>	-	65	65	79	92*	114	N204	10	4	15.5	23.75	11.25	24	12.62	8	
	-	20	20	36	42	52		254	102	394	603	286	610	321	203	
<b>N716-23-24-15.5G</b>	100	75	65	94	101*	129	N204	10	4	15.5	23.75	11.25	24	12.62	8	
	30	23	20	43	46	59		254	102	394	603	286	610	321	203	
<b>N716-25-26-15.5B</b>	-	75	75	90	-	125	N204	10	4	15.5	25.25	11.25	26	13.62	8	
	-	23	23	41	-	57		254	102	394	641	286	660	346	203	
<b>N718-25-26-15.5G</b>	-	100	100	96	-	131	N206	12	6	15.5	25.25	13.25	26	13.62	10	
	-	30	30	44	-	59		305	152	394	641	337	660	346	254	

**Notes:**

**A hose stop is necessary to keep spring from unwinding.**

1. Specifications subject to change.
2. Reel models and capacities shown are for standard drag applications; for vertical lift applications, consult factory.
3. Other sizes, from standard components, available on request.
4. **Finish:** Refer to page 3.

5. **Be sure to check dimensions and weights prior to ordering.**

**NOTICE:** A flexible connector must be used between the inlet pipe and the inlet swivel joint.  
 \*Dimensional weight may apply when shipped as a parcel package (via FedEx or UPS Ground).  
 \*\*\*X, Y indicate mounting holes. See page 5.  
 †Capacity based on low pressure air hose only.  
 Not for vertical lift applications.

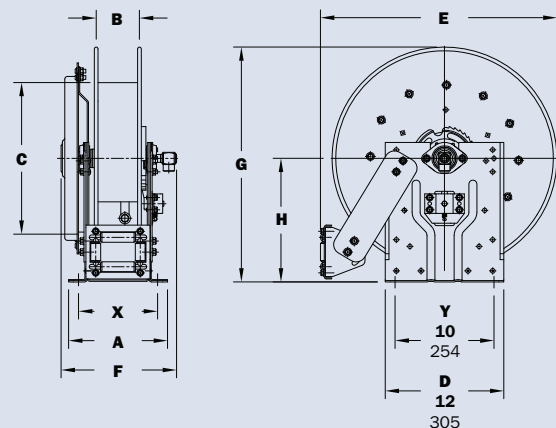

**Available Roller Positions**

