

# Series 1500

- Lawn Care • Pest Control • Pressure Washing
- Agriculture • Steam Cleaning

**To handle single 1/4" through 5/8" I.D. hose.**

- Lightweight, compact reels designed for long lengths of hose in manual and power rewind.
- Direct crank rewind is permanently attached.
- Chain and sprocket drive powered by electric, hydraulic or compressed air motor.
- Manual reels include cam-lock drag brake, spring actuated pin lock.
- Standard inlet: 90° ball bearing swivel joint, 1/2" female NPT threads.
- Standard outlet: 1/2" female NPT threads.
- Optional rollers: Specify roller position when ordering.
- Standard pressures to 3000 psi (207 bar), available up to 10,000 psi (690 bar) – must specify.
- Temperatures from +20°F to +400°F (-7°C to +204°C).



Crank rewind  
Standard configuration shown



**Optional External Mounting Brackets**

Part No. 9906.0027.  
Add 2-1/2" to the X dimensions shown in the chart.

**PARTS DRAWING – ISO 90 (POWER); ISO 179 (MANUAL)**

Model Number <small>For power rewind see Note 5</small>	Hose Capacity of Reel feet m					Approx. Weight Crank Rewind lb. kg <small>see Note 3</small>			Reel Dimensions*** in. mm						
	I.D. in. mm	1/4 6	3/8 10	1/2 13	5/8 16	NET	UPS/ FedEx SHIP Wt.	Freight SHIP Wt.	A	B	E CRANK	E POWER	F CRANK	F POWER	X
	O.D. in. mm	5/8 16	3/4 19	7/8 22	1 25										
<b>1514-17-18</b>		<b>175</b> 53	<b>125</b> 38	<b>75</b> 23	<b>50</b> 15	<b>27</b> 12	<b>65*</b> 30	<b>62</b> 28	<b>11</b> 279	<b>6</b> 152	<b>16.5</b> 419	<b>19</b> 483	<b>18.5</b> 470	<b>16.5</b> 419	<b>9.5</b> 241
<b>1520-17-18</b>		<b>350</b> 107	<b>275</b> 84	<b>175</b> 53	<b>125</b> 38	<b>29</b> 13	<b>80*</b> 36	<b>64</b> 29	<b>17</b> 432	<b>12</b> 305	<b>16.5</b> 419	<b>19</b> 483	<b>24.5</b> 622	<b>22.5</b> 572	<b>15.5</b> 394
<b>1526-17-18</b>		<b>500</b> 152	<b>400</b> 122	<b>300</b> 91	<b>200</b> 61	<b>31</b> 14	<b>98*</b> 45	<b>66</b> 30	<b>23</b> 584	<b>18</b> 457	<b>16.5</b> 419	<b>19</b> 483	<b>30.5</b> 775	<b>28.5</b> 724	<b>21.5</b> 546
<b>1530-17-18</b>		-	<b>500</b> 152	<b>375</b> 114	<b>275</b> 84	<b>33</b> 15	<b>110*</b> 50	<b>68</b> 31	<b>27</b> 686	<b>22</b> 559	<b>16.5</b> 419	<b>19</b> 483	<b>34.5</b> 876	<b>32.5</b> 826	<b>25.5</b> 648
<b>1536-17-18</b>		-	-	<b>475</b> 145	<b>350</b> 107	<b>35</b> 16	<b>129*</b> 59	<b>70</b> 32	<b>33</b> 838	<b>28</b> 711	<b>16.5</b> 419	<b>19</b> 483	<b>40.5</b> 1029	<b>38.5</b> 978	<b>31.5</b> 800

**Notes:**

1. Specifications subject to change.
2. Upon request, reels can be supplied with drum lengths other than shown.
3. Weights shown in chart are for crank rewind models. ADD these amounts for power rewind models (does not apply to FedEx or UPS):

	Net lbs/kg	Ship lbs/kg
<b>Electric</b>	<b>18/8.2</b>	<b>18/8.2</b>
<b>Hydraulic</b>	<b>15/6.8</b>	<b>15/6.8</b>
<b>Air</b>	<b>15/6.8</b>	<b>15/6.8</b>

4. Dimension "F" is the overall length of standard model reels.
5. When ordering power rewind models, prefix model number with:
  - A** = Air Rewind
  - E** = Electric Rewind
  - HD** = Hydraulic Rewind

(Air rewind reels are supplied with control valve and 18" air hose; 12v and 24v DC rewind reels are supplied with switch and solenoid; 115v AC rewind reels are not supplied with switch but can be ordered separately; hydraulic rewind reels are not supplied with control valve.)

6. Manual rewind available in RT or LB configurations only.
  7. **Finish:** Refer to page 3.
  8. **Be sure to check dimensions and weights prior to ordering.**
  9. Some roller options may prohibit the use of our molded chain guard.
- NOTICE:** A flexible connector must be used between the inlet pipe and the inlet swivel joint.
- \* Dimensional weight applies when shipped as a parcel package (via FedEx or UPS Ground).
- \*\*\* X, Y indicate mounting holes. See page 5.

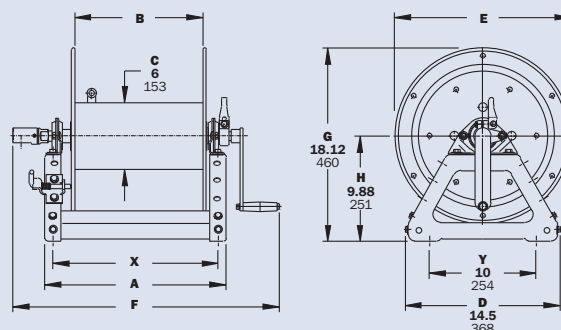

Crank rewind shown