

Series **1100/AT1200**

- Grounds Maintenance • Restaurants/Hotels
- Washdown Operations • Home Use

To handle 3/8" through 1" I.D. hose.

- Continuous flow reels with swivel joint inlet, fluid hub, outlet riser.
- Direct crank rewind and cam-lock brake.
- One-piece foot and removable steel handlebar.
- Permanently attached crank.
- **GH** prefix to model number (e.g., GH1100, GHAT1200) includes garden hose thread on outlet, 5' lead-in hose, hose end clips.

Model 1100

- Standard inlet: 90° ball bearing swivel joint, 1/2" female NPT threads.
- Standard outlet: 1/2" female NPT threads.
- Pressures to 3000 psi (207 bar).
- Temperatures from +20°F to +400°F (-7°C to +204°C).
- Rubber tires standard.

Model AT1200

- Standard inlet: 90° balance pressure swivel joint, 1" female NPT threads.
- Standard outlet: 1" female NPT threads.
- Standard pressures to 2000 psi (138 bar), available up to 4000 psi (276 bar) – must specify.
- Temperatures from -40°F to +250°F (-40°C to +121°C).
- Pneumatic tires standard.



PARTS DRAWING – 1100–ISO 48; AT1200–ISO 87

Model Number	Hose Capacity of Reel feet m						Approx. Weight lb. kg		Reel Dimensions in. mm							
	I.D. in. mm	3/8	1/2	5/8	3/4	1	NET	SHIP	A	B	C	D	E	F	G	H
	O.D. in. mm	3/4	7/8	1	1-9/32	1-9/16										
1100		275	175	125	–	–	47	100*	21.5	12	6	21	16.5	24.62	39	13.81
		84	53	38	–	–	21	46	54.6	305	152	533	419	625	991	351
AT1200		–	350	250	150	100	86	147*	24.88	11.5	8	23.31	22.75	26.5	40	17.25
		–	107	76	46	30	39	67	632	292	203	592	578	673	1016	438

Notes:

1. Specifications subject to change.
2. Some assembly required.
3. **Finish:** Refer to page 3.
4. **Be sure to check dimensions and weights prior to ordering.**

*Dimensional weight applies when shipped as a parcel package (via FedEx or UPS Ground).

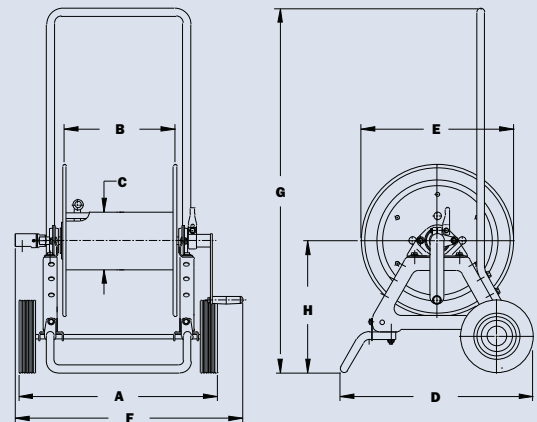

GH1100 shown